

Isometric View

18" Long Leads
18 Ga. Type 1015 UL

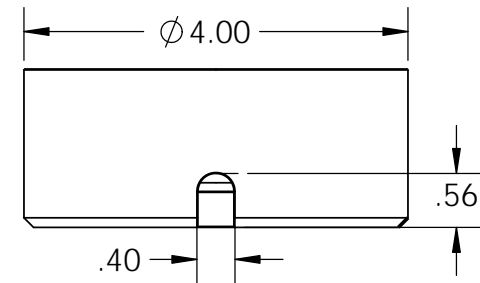
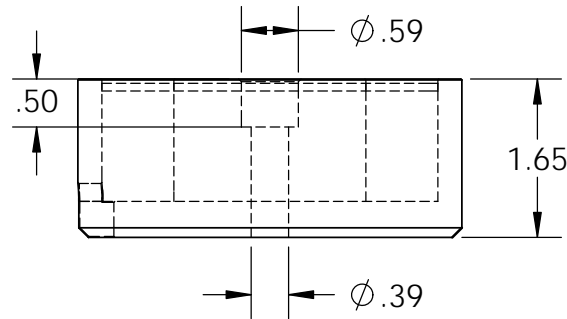

Electrical Specifications

- Voltage:** 6 VDC
- Duty Cycle:** Continuous
- Resistance:** 1.95 ohms ± 10% (@ 20c)
- Amps @ rated Volts:** 3.33
- Watts @ rated Volts:** 20.0
- Holding:** 640 lbs (1/4" Thick 1215 CRS @ 20c)
- Operating Temp:** -40c to 60c (range)

Additional Components

- Screw:** 3/8-16 x 1 3/4" Long (Hex Socket Head Cap) w/Nylok
- Spring:** N/A
- Spiral Pin:** N/A
- Potting:** United Resin Corp. (El-cast Black)
- Finish:** Housing - Zinc or Electroless Nickel Plating (0.0002-0.0003")

∅ .39 THRU ALL
 □ ∅ .59 ▽ .50
 ✓ ∅ .65 X 90°, NEAR SIDE

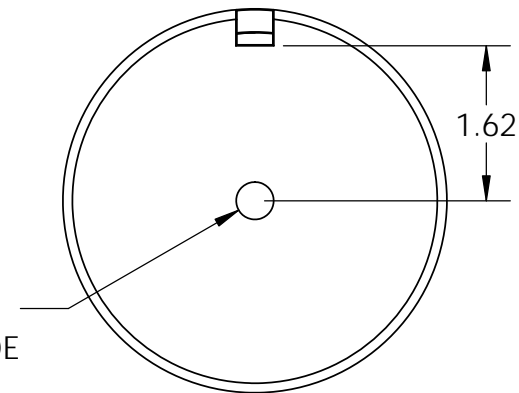

PROPRIETARY AND CONFIDENTIAL
 THE INFORMATION CONTAINED IN THIS DRAWING IS THE SOLE PROPERTY OF APW COMPANY. ANY REPRODUCTION IN PART OR AS A WHOLE WITHOUT THE WRITTEN PERMISSION OF APW COMPANY IS PROHIBITED.

		UNLESS OTHERWISE SPECIFIED:		NAME	DATE
		DIMENSIONS ARE IN INCHES TOLERANCES: FRACTIONAL ± .015 ANGULAR: MACH ± 2 BEND ± 2 TWO PLACE DECIMAL ± .005 THREE PLACE DECIMAL ± .003	DRAWN	K.H.	06.17.11
		INTERPRET GEOMETRIC TOLERANCING PER: ANSI	CHECKED	J.K.	06.17.11
		MATERIAL	ENG APPR.	J.K.	06.17.11
		FINISH	MFG APPR.	J.K.	06.17.11
NEXT ASSY	USED ON		Q.A.		
APPLICATION		DO NOT SCALE DRAWING	COMMENTS:		

APW COMPANY		
TITLE: P/N: EM400-6-212		
SIZE A	DWG. NO. 4840	REV
SCALE: 1:2	WEIGHT:	SHEET 1 OF 1