

Isometric View

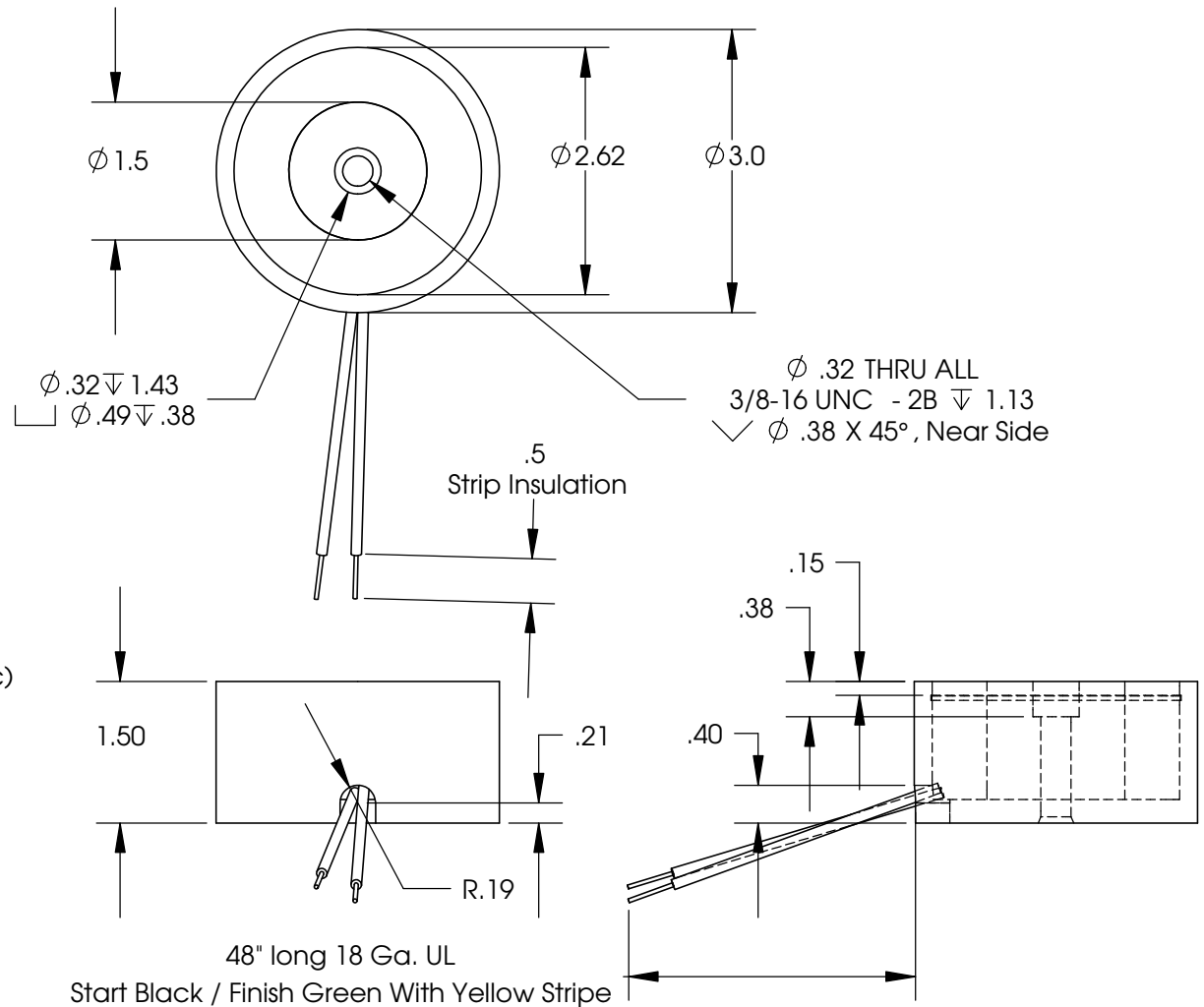

Electrical Specifications

- Voltage:** 12 vac
- Duty Cycle:** Continuous
- Resistance:** 10.5 ohms ± 10% (@ 20c)
- Amps @ 12 vac:** 1.2
- Watts @ 12 vac:** 15
- Holding:** 360 lbs (1/4" Thick 1215 CRS @ 20c)
- Operating Temp:** -40c to 50c (range)
- Note:** Resistance can not be checked after assembly*

Additional Components

- Screw: N/A
- Spring: N/A
- Spiral Pin: N/A
- Potting: N/A
- Rectified: Yes (Internally)*
- RoHS: Yes (compliant)

Finish: Housing - Zinc or Electroless Nickel Plating (0.0002-0.0003")

48" long 18 Ga. UL
Start Black / Finish Green With Yellow Stripe

PROPRIETARY AND CONFIDENTIAL
THE INFORMATION CONTAINED IN THIS DRAWING IS THE SOLE PROPERTY OF APW COMPANY INCORPORATED. ANY REPRODUCTION IN PART OR AS A WHOLE WITHOUT THE WRITTEN PERMISSION OF APW COMPANY INCORPORATED IS STRICTLY PROHIBITED.

Client	Client P/N	UNLESS OTHERWISE SPECIFIED:	NAME	DATE
Stearns Products	10045360023	DIMENSIONS ARE IN INCHES TOLERANCES: FRACTIONAL ± .010 ANGULAR: MACH ± BEND ± TWO PLACE DECIMAL ±.010 THREE PLACE DECIMAL ±.005	DRAWN CHECKED ENG APPR. MFG APPR.	J.K. A.P.
		Break Sharp edges 0.005" unless otherwise noted	Q.A.	
		MATERIAL	COMMENTS: Not for manufacturing	
		FINISH		
NEXT ASSY	USED ON			
APPLICATION		DO NOT SCALE DRAWING		

APW COMPANY INC.		
TITLE: EM300-12ac-222-A		
SIZE A	DWG. NO. 6328	REV
SCALE: 1:2	WEIGHT:	SHEET 1 OF 1