

Electrical Specifications

Voltage: 24 VDC
Duty Cycle: Continuous
Resistance: 40 ohms \pm 10% (@ 20c)
Amps @ rated Volts: 0.63
Watts @ rated Volts: 15.0
Holding: 400 lbs (1/4" Thick 1215 CRS @ 20c)
Operating Temp: -40c to 60c (range)

Additional Components

Screw: 5/16-18 x 1 1/2" Long (Socket Head Cap Screw) w/Nylok
Spring: N/A
Spiral Pin: N/A
Potting: N/A

Finish: Housing - Zinc or Electroless Nickel Plating
 (0.0002-0.0003")

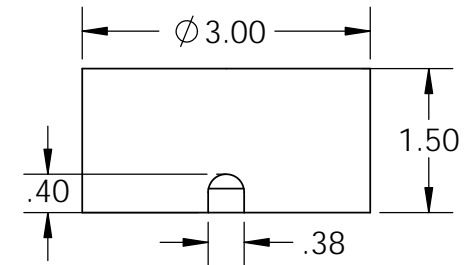
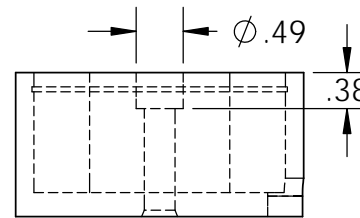

18" Long Leads
 18 Ga. Type 1015 UL

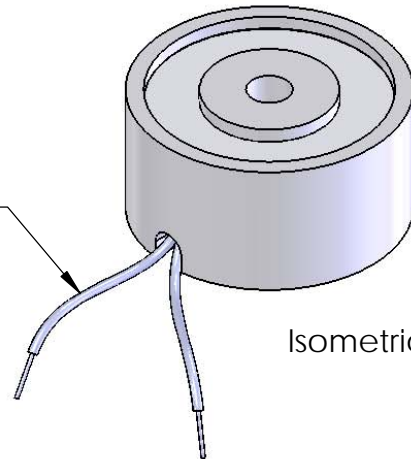

Isometric View

ϕ .32 THRU ALL
 3/8-16 UNC - 2B ∇ 1.13
 \checkmark ϕ .38 X 45°, NEAR SIDE

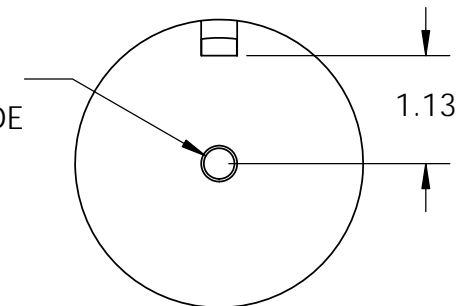

PROPRIETARY AND CONFIDENTIAL
 THE INFORMATION CONTAINED IN THIS DRAWING IS THE SOLE PROPERTY OF APW COMPANY. ANY REPRODUCTION IN PART OR AS A WHOLE WITHOUT THE WRITTEN PERMISSION OF APW COMPANY IS PROHIBITED.

		UNLESS OTHERWISE SPECIFIED:		NAME	DATE
		DIMENSIONS ARE IN INCHES TOLERANCES: FRACTIONAL \pm .015 ANGULAR: MACH \pm 2 BEND \pm 2 TWO PLACE DECIMAL \pm .005 THREE PLACE DECIMAL \pm .003	DRAWN	K.H.	07.15.11
			CHECKED	J.K.	07.15.11
			ENG APPR.	J.K.	07.15.11
			MFG APPR.	J.K.	07.15.11
		INTERPRET GEOMETRIC TOLERANCING PER: ANSI	Q.A.		
		MATERIAL	COMMENTS:		
		FINISH			
NEXT ASSY	USED ON				
APPLICATION		DO NOT SCALE DRAWING			

APW COMPANY

TITLE:

P/N: EM300-24-222

SIZE
A

DWG. NO.
6285

REV

SCALE: 1:2

WEIGHT:

SHEET 1 OF 1