

Isometric View

18" Long Leads
18 Ga. Type UL 1015

Center Post Recessed
(.003-.005)
Quick Release

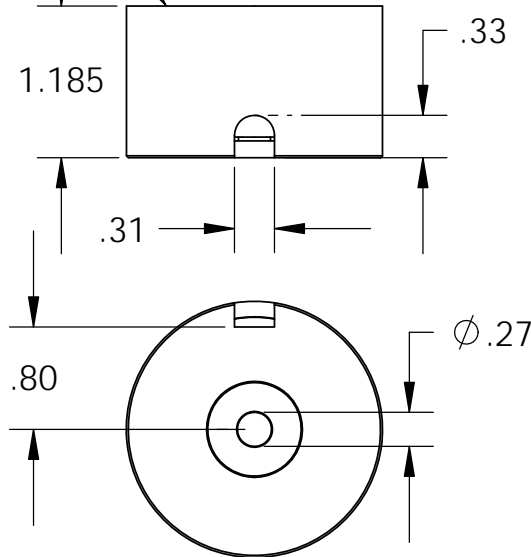
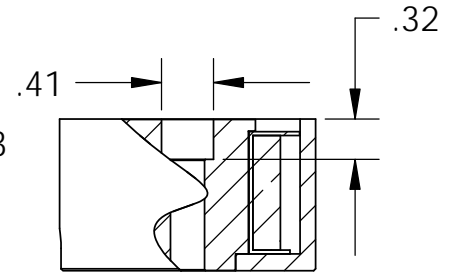
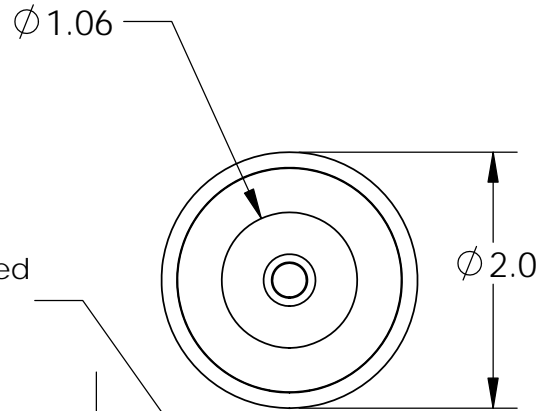

Electrical Specifications

Voltage: 12 VDC
Duty Cycle: Continuous
Resistance: 20.5 ohms ± 10% (@ 20c)
Amps @ rated Volts: 0.58
Watts @ rated Volts: 7.0
Holding: 105 lbs (1/4" Thick 1215 CRS @ 20c)
Operating Temp: -40c to 60c (range)

Additional Components

Screw: 1/4-20 x 1 1/4" Long (Hex Socket Head Cap) w/Nylok
Spring: N/A
Spiral Pin: N/A
Potting: N/A
Finish: Housing - Zinc or Electroless Nickel Plating (0.0002-0.0003")

PROPRIETARY AND CONFIDENTIAL
 THE INFORMATION CONTAINED IN THIS DRAWING IS THE SOLE PROPERTY OF APW COMPANY. ANY REPRODUCTION IN PART OR AS A WHOLE WITHOUT THE WRITTEN PERMISSION OF APW COMPANY IS PROHIBITED.

		UNLESS OTHERWISE SPECIFIED:		NAME	DATE
		DIMENSIONS ARE IN INCHES	DRAWN	K.H.	07.14.11
		TOLERANCES:	CHECKED	J.K.	07.14.11
		FRACTIONAL ± .015	ENG APPR.	J.K.	07.14.11
		ANGULAR: MACH ± 2 BEND ± 2	MFG APPR.	J.K.	07.14.11
		TWO PLACE DECIMAL ± .005	Q.A.		
		THREE PLACE DECIMAL ± .003	COMMENTS:		
		INTERPRET GEOMETRIC TOLERANCING PER: ANSI			
		MATERIAL			
NEXT ASSY	USED ON	FINISH			
APPLICATION		DO NOT SCALE DRAWING			

APW COMPANY

TITLE:
P/N: EM200-12-122

SIZE A	DWG. NO. 6076	REV
SCALE: 2:3	WEIGHT:	SHEET 1 OF 1