

Isometric View

18" Long Leads
18 Ga. Type UL 1015

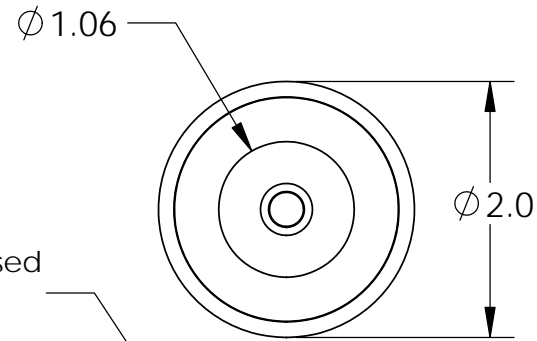

Center Post Recessed
(.003-.005)
Quick Release

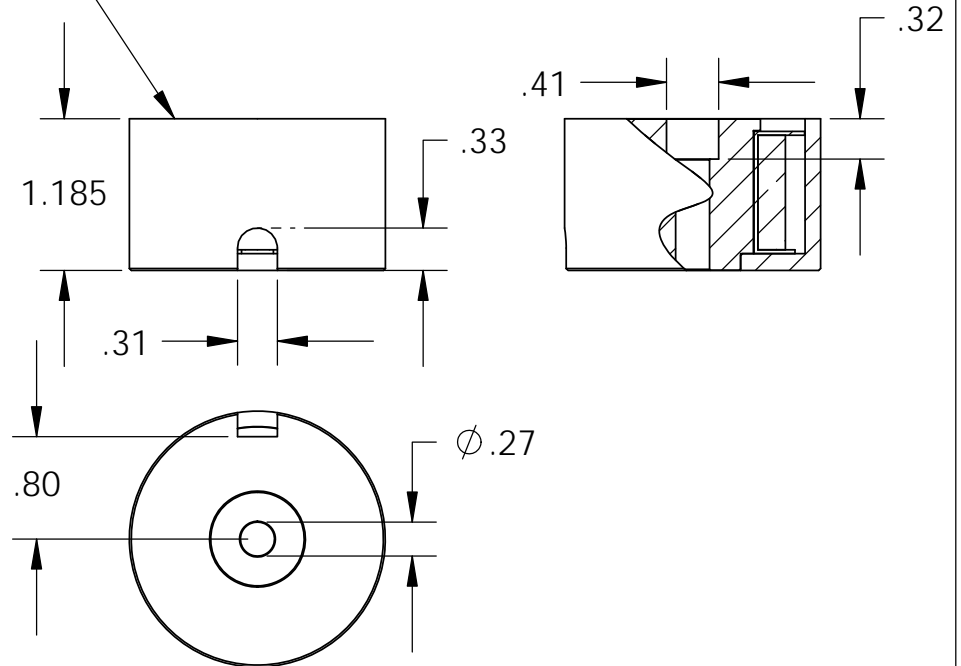

Electrical Specifications

- Voltage:** 110 VDC
- Duty Cycle:** Continuous
- Resistance:** 1388 ohms \pm 10% (@ 20c)
- Amps @ rated Volts:** 0.06
- Watts @ rated Volts:** 7.0
- Holding:** 105 lbs (1/4" Thick 1215 CRS @ 20c)
- Operating Temp:** -40c to 60c (range)

Additional Components

- Screw:** 1/4-20 x 1 1/4" Long (Hex Socket Head Cap) w/Nylok
- Spring:** N/A
- Spiral Pin:** N/A
- Potting:** N/A

Finish: Housing - Zinc or Electroless Nickel Plating
(0.0002-0.0003")

PROPRIETARY AND CONFIDENTIAL
THE INFORMATION CONTAINED IN THIS DRAWING IS THE SOLE PROPERTY OF APW COMPANY. ANY REPRODUCTION IN PART OR AS A WHOLE WITHOUT THE WRITTEN PERMISSION OF APW COMPANY IS PROHIBITED.

		UNLESS OTHERWISE SPECIFIED:		NAME	DATE
		DIMENSIONS ARE IN INCHES	DRAWN	K.H.	07.14.11
		TOLERANCES:	CHECKED	J.K.	07.14.11
		FRACTIONAL \pm .015	ENG APPR.	J.K.	07.14.11
		ANGULAR: MACH \pm 2 BEND \pm 2	MFG APPR.	J.K.	07.14.11
		TWO PLACE DECIMAL \pm .005	Q.A.		
		THREE PLACE DECIMAL \pm .003	COMMENTS:		
		INTERPRET GEOMETRIC TOLERANCING PER: ANSI			
		MATERIAL			
NEXT ASSY	USED ON	FINISH			
APPLICATION		DO NOT SCALE DRAWING			

APW COMPANY		
TITLE: P/N: EM200-110-122		
SIZE A	DWG. NO. 6074	REV
SCALE: 2:3	WEIGHT:	SHEET 1 OF 1