

Electrical Specifications

Voltage: 24 VDC
Duty Cycle: Continuous
Resistance: 110 ohms \pm 10% (@ 20c)
Amps @ rated Volts: 0.25
Watts @ rated Volts: 6.0
Holding: 100 lbs (1/4" Thick 1215 CRS @ 20c)
Operating Temp: -40c to 60c (range)

Additional Components

Screw: 1/4-20 x 1 1/4" Long (Hex Socket Head Cap) w/Nylok
Spring: N/A
Spiral Pin: N/A
Potting: N/A

Finish: Housing - Zinc or Electroless Nickel Plating
 (0.0002-0.0003")

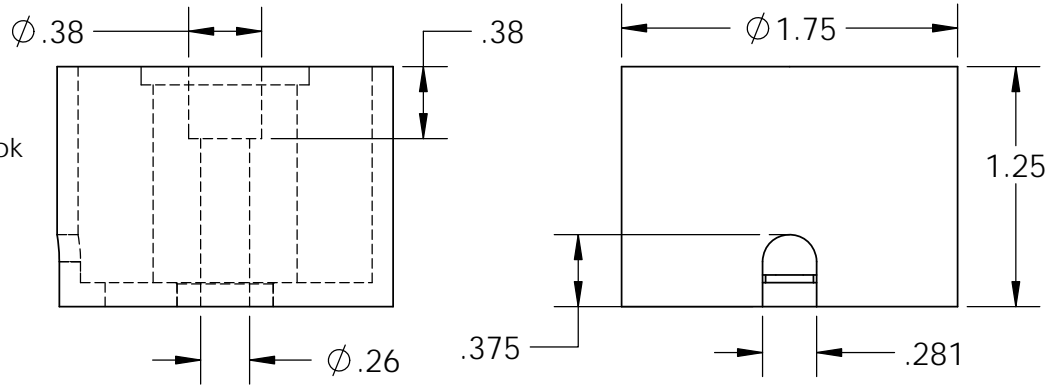

18" Long Leads
 18 Ga. Type 1015 UL

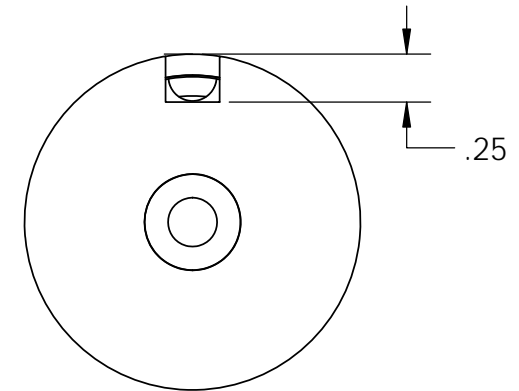
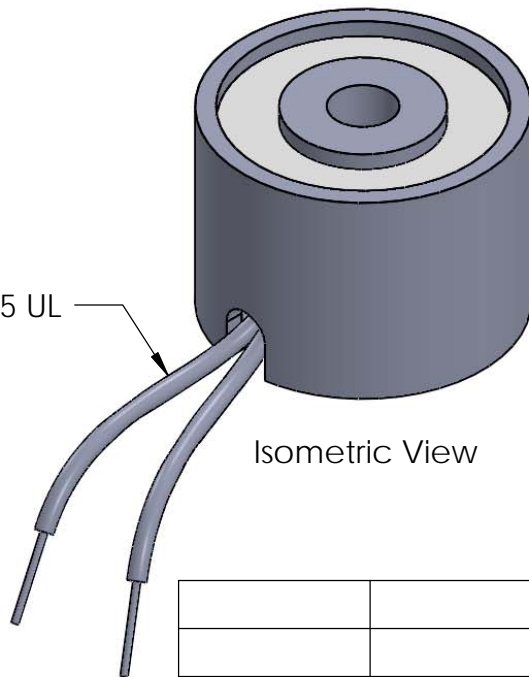

PROPRIETARY AND CONFIDENTIAL
 THE INFORMATION CONTAINED IN THIS DRAWING IS THE SOLE PROPERTY OF APW COMPANY. ANY REPRODUCTION IN PART OR AS A WHOLE WITHOUT THE WRITTEN PERMISSION OF APW COMPANY IS PROHIBITED.

		UNLESS OTHERWISE SPECIFIED:	NAME	DATE
		DIMENSIONS ARE IN INCHES	DRAWN	K.H. 06.21.11
		TOLERANCES:	CHECKED	J.K. 06.21.11
		FRACTIONAL $\pm .015$	ENG APPR.	J.K. 06.21.11
		ANGULAR: MACH ± 2 BEND ± 2	MFG APPR.	J.K. 06.21.11
		TWO PLACE DECIMAL $\pm .005$	Q.A.	
		THREE PLACE DECIMAL $\pm .003$	COMMENTS:	
		INTERPRET GEOMETRIC TOLERANCING PER: ANSI		
		MATERIAL		
NEXT ASSY	USED ON	FINISH		
APPLICATION		DO NOT SCALE DRAWING		

APW COMPANY		
TITLE:		
P/N: EM175-24-222-A		
SIZE	DWG. NO.	REV
A	5755	
SCALE: 1:1	WEIGHT:	SHEET 1 OF 1