

Isometric View

18" Long Leads  
18 Ga. Type 1015 UL

Center Post Recessed  
(.003-.005)  
Quick Release

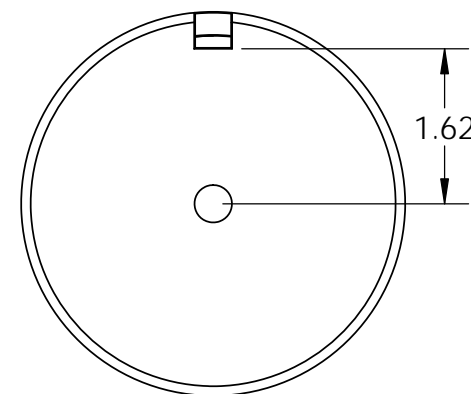
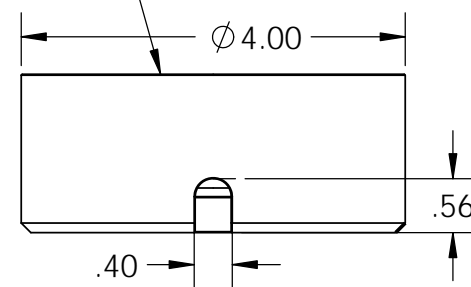
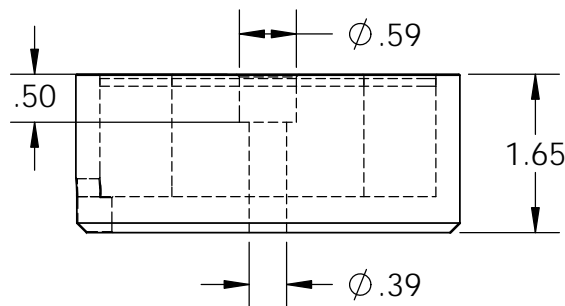

**Electrical Specifications**

- Voltage:** 12 VDC
- Duty Cycle:** Continuous
- Resistance:** 7.8 ohms ± 10% (@ 20c)
- Amps @ rated Volts:** 1.67
- Watts @ rated Volts:** 20.0
- Holding:** 480 lbs (1/4" Thick 1215 CRS @ 20c)
- Operating Temp:** -40c to 60c (range)

**Additional Components**

- Screw:** 3/8-16 x 1 3/4" Long (Hex Socket Head Cap) w/Nylok
- Spring:** N/A
- Spiral Pin:** N/A
- Potting:** United Resin Corp. (El-cast Black)
- Finish:** Housing - Zinc or Electroless Nickel Plating (0.0002-0.0003")

**PROPRIETARY AND CONFIDENTIAL**  
THE INFORMATION CONTAINED IN THIS DRAWING IS THE SOLE PROPERTY OF APW COMPANY. ANY REPRODUCTION IN PART OR AS A WHOLE WITHOUT THE WRITTEN PERMISSION OF APW COMPANY IS PROHIBITED.

		UNLESS OTHERWISE SPECIFIED:		NAME	DATE
		DIMENSIONS ARE IN INCHES	DRAWN	K.H.	06.17.11
		TOLERANCES:	CHECKED	J.K.	06.17.11
		FRACTIONAL ± .015	ENG APPR.	J.K.	06.17.11
		ANGULAR: MACH ± 2 BEND ± 2	MFG APPR.	J.K.	06.17.11
		TWO PLACE DECIMAL ± .005	Q.A.		
		THREE PLACE DECIMAL ± .003	COMMENTS:		
		INTERPRET GEOMETRIC TOLERANCING PER: ANSI			
		MATERIAL			
NEXT ASSY	USED ON	FINISH			
APPLICATION		DO NOT SCALE DRAWING			

<b>APW COMPANY</b>		
TITLE: P/N: EM400-12-112		
SIZE <b>A</b>	DWG. NO. <b>5558</b>	REV
SCALE: 1:2	WEIGHT:	SHEET 1 OF 1