

Isometric View

8" from coil to Recifier. 11" after  
22 Ga. Teflon Type E

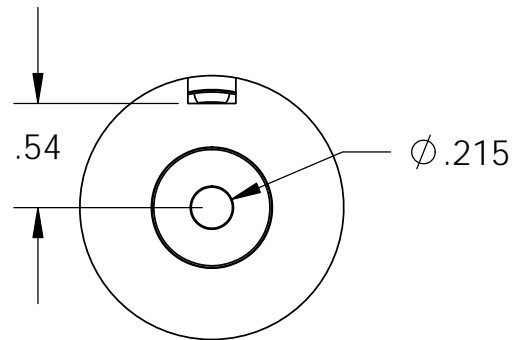
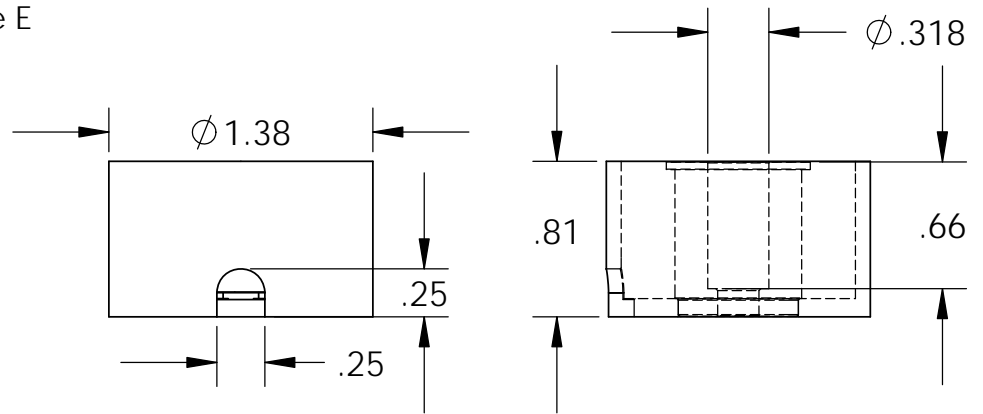

**Electrical Specifications**

- Voltage:** 6 VDC
- Duty Cycle:** Continuous
- Resistance:** 9.5 ohms ± 10% (@ 20c)
- Amps @ rated Volts:** 0.83
- Watts @ rated Volts:** 5.0
- Holding:** 44 lbs (1/4" Thick 1215 CRS @ 20c)
- Operating Temp:** -40c to 60c (range)

**Additional Components**

- Screw:** 10-32 x 13/16" Long (Hex Socket Head Cap) w/Nylok
- Spring:** N/A
- Spiral Pin:** N/A
- Potting:** N/A

**Finish:** Housing - Zinc or Electroless Nickel Plating  
(0.0002-0.0003")

**PROPRIETARY AND CONFIDENTIAL**  
THE INFORMATION CONTAINED IN THIS DRAWING IS THE SOLE PROPERTY OF APW COMPANY. ANY REPRODUCTION IN PART OR AS A WHOLE WITHOUT THE WRITTEN PERMISSION OF APW COMPANY IS PROHIBITED.

		UNLESS OTHERWISE SPECIFIED:		NAME	DATE
		DIMENSIONS ARE IN INCHES	DRAWN	K.H.	07.20.11
		TOLERANCES:	CHECKED	J.K.	07.20.11
		FRACTIONAL ± .015	ENG APPR.	J.K.	07.20.11
		ANGULAR: MACH ± 2 BEND ± 2	MFG APPR.	J.K.	07.20.11
		TWO PLACE DECIMAL ± .005	Q.A.		
		THREE PLACE DECIMAL ± .003	COMMENTS:		
		INTERPRET GEOMETRIC TOLERANCING PER: ANSI			
		MATERIAL			
NEXT ASSY	USED ON	FINISH			
APPLICATION		DO NOT SCALE DRAWING			

<b>APW COMPANY</b>		
TITLE: P/N: EM137-6-222		
SIZE <b>A</b>	DWG. NO. <b>5474</b>	REV
SCALE: 1:1	WEIGHT:	SHEET 1 OF 1