

Electrical Specifications

Voltage: 6 VDC
Duty Cycle: Continuous
Resistance: 2.56 ohms \pm 10% (@ 20c)
Amps @ rated Volts: 2.50
Watts @ rated Volts: 15.0
Holding: 400 lbs (1/4" Thick 1215 CRS @ 20c)
Operating Temp: -40c to 60c (range)

Additional Components

Screw: 5/16-18 x 1 1/2" Long (Socket Head Cap Screw) w/Nylok
Spring: N/A
Spiral Pin: N/A
Potting: United Resin Corp. (EI-cast Black)
Finish: Housing - Zinc or Electroless Nickel Plating (0.0002-0.0003")

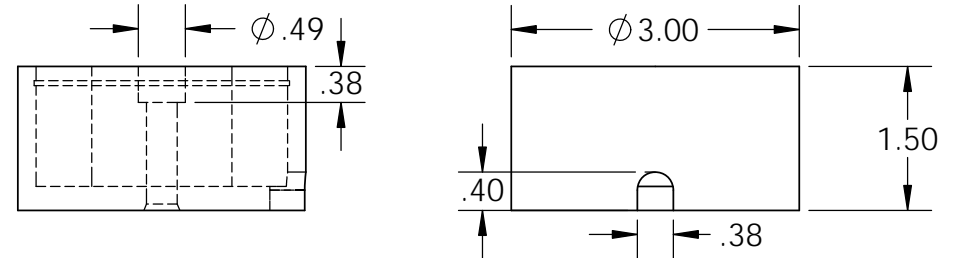

18" Long Leads
 18 Ga. Type 1015 UL

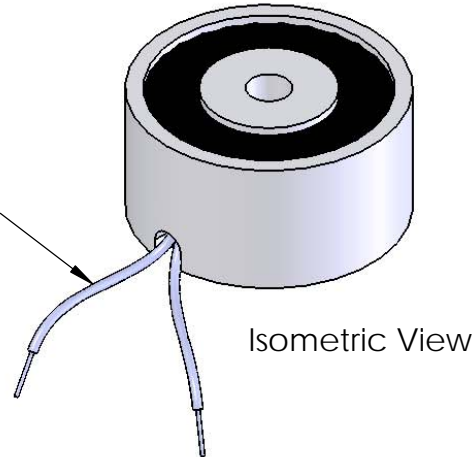

ϕ .32 THRU ALL
 3/8-16 UNC - 2B ∇ 1.13
 \checkmark ϕ .38 X 45°, NEAR SIDE

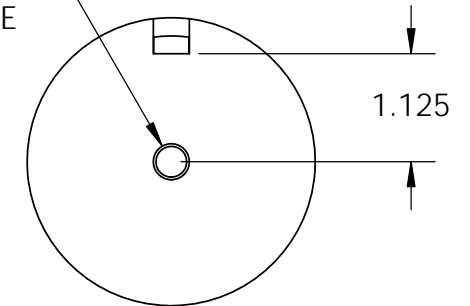

PROPRIETARY AND CONFIDENTIAL
 THE INFORMATION CONTAINED IN THIS DRAWING IS THE SOLE PROPERTY OF APW COMPANY. ANY REPRODUCTION IN PART OR AS A WHOLE WITHOUT THE WRITTEN PERMISSION OF APW COMPANY IS PROHIBITED.

		UNLESS OTHERWISE SPECIFIED:		NAME	DATE	APW COMPANY	
		DIMENSIONS ARE IN INCHES TOLERANCES: FRACTIONAL \pm .015 ANGULAR: MACH \pm 2 BEND \pm 2 TWO PLACE DECIMAL \pm .005 THREE PLACE DECIMAL \pm .003		DRAWN	K.H.		
		INTERPRET GEOMETRIC TOLERANCING PER: ANSI		CHECKED	J.K.	07.15.11	TITLE: P/N: EM300-6-212
		MATERIAL		ENG APPR.	J.K.	07.15.11	
		FINISH		MFG APPR.	J.K.	07.15.11	
NEXT ASSY	USED ON			Q.A.			
APPLICATION		DO NOT SCALE DRAWING		COMMENTS:		SIZE A	DWG. NO. 4786
						SCALE: 1:2	WEIGHT:
						REV	
						SHEET 1 OF 1	