

## Electrical Specifications

**Voltage:** 230 VAC  
**Duty Cycle:** Continuous  
**Resistance:** 2624 ohms  $\pm$  10% (@ 20c)  
**Amps @ rated Volts:** 0.07  
**Watts @ rated Volts:** 15.0  
**Holding:** 400 lbs (1/4" Thick 1215 CRS @ 20c)  
**Operating Temp:** -40c to 60c (range)

## Additional Components

**Screw:** 5/16-18 x 1 1/2" Long (Socket Head Cap Screw) w/Nylok  
**Spring:** N/A  
**Spiral Pin:** N/A  
**Potting:** United Resin Corp. (EI-cast Black)  
**Finish:** Housing - Zinc or Electroless Nickel Plating (0.0002-0.0003")

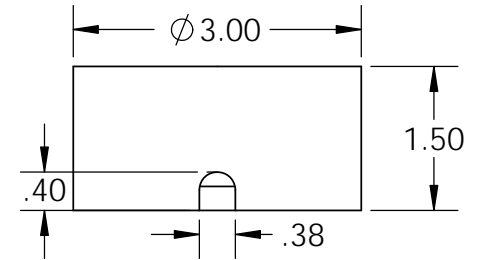
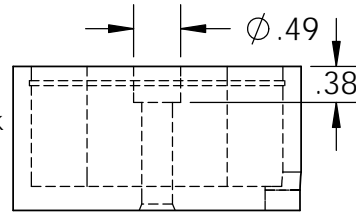

18" from coil to rectifier 11" after 18 Ga. Type 1015 UL

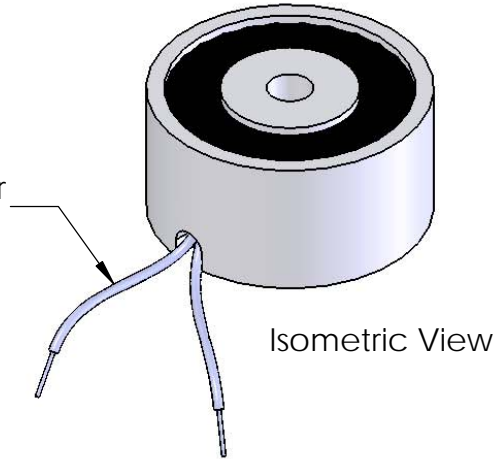

$\phi$  .32 THRU ALL  
 3/8-16 UNC - 2B  $\nabla$  1.13  
 $\checkmark$   $\phi$  .38 X 45°, NEAR SIDE

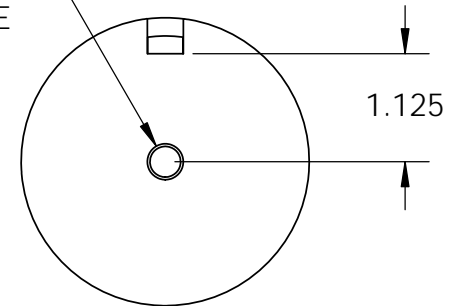

**PROPRIETARY AND CONFIDENTIAL**  
 THE INFORMATION CONTAINED IN THIS DRAWING IS THE SOLE PROPERTY OF APW COMPANY. ANY REPRODUCTION IN PART OR AS A WHOLE WITHOUT THE WRITTEN PERMISSION OF APW COMPANY IS PROHIBITED.

		UNLESS OTHERWISE SPECIFIED:	NAME	DATE
		DIMENSIONS ARE IN INCHES TOLERANCES: FRACTIONAL $\pm$ .015 ANGULAR: MACH $\pm$ 2 BEND $\pm$ 2 TWO PLACE DECIMAL $\pm$ .005 THREE PLACE DECIMAL $\pm$ .003	DRAWN	K.H. 07.15.11
			CHECKED	J.K. 07.15.11
			ENG APPR.	J.K. 07.15.11
			MFG APPR.	J.K. 07.15.11
		INTERPRET GEOMETRIC TOLERANCING PER: ANSI	Q.A.	
		MATERIAL	COMMENTS:	
		FINISH		
NEXT ASSY	USED ON			
APPLICATION		DO NOT SCALE DRAWING		

<b>APW COMPANY</b>		
TITLE: P/N: EM300-230ac-212		
SIZE <b>A</b>	DWG. NO. <b>4779</b>	REV
SCALE: 1:2	WEIGHT:	SHEET 1 OF 1