

## Electrical Specifications

**Voltage:** 6 VDC  
**Duty Cycle:** Continuous  
**Resistance:** 6 ohms  $\pm$  10% (@ 20c)  
**Amps @ rated Volts:** 1.0  
**Watts @ rated Volts:** 6.0  
**Holding:** 88 lbs (1/4" Thick 1215 CRS @ 20c)  
**Operating Temp:** -40c to 60c (range)

## Additional Components

**Screw:** 10-32 x 1 1/4" Long (Hex Socket Head Cap) w/Nylok  
**Spring:** N/A  
**Spiral Pin:** N/A  
**Potting:** United Resin Corp. (El-cast Black)

**Finish:** Housing - Zinc or Electroless Nickel Plating  
 (0.0002-0.0003")

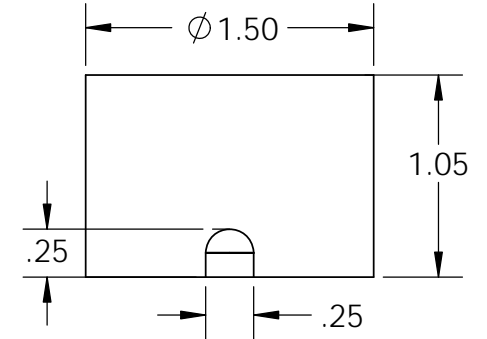
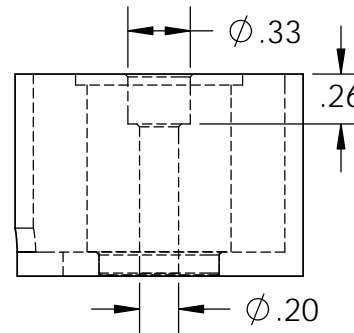

18" Long Leads  
22 Ga. Type 1015 UL

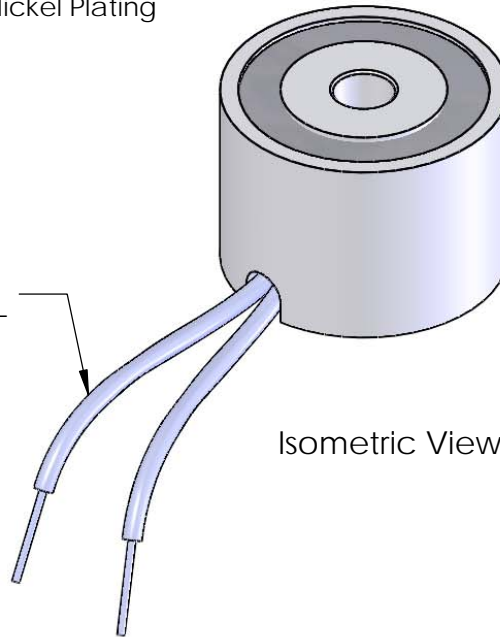

Isometric View

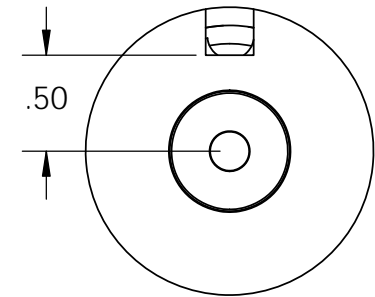

**PROPRIETARY AND CONFIDENTIAL**  
THE INFORMATION CONTAINED IN THIS DRAWING IS THE SOLE PROPERTY OF APW COMPANY. ANY REPRODUCTION IN PART OR AS A WHOLE WITHOUT THE WRITTEN PERMISSION OF APW COMPANY IS PROHIBITED.

		UNLESS OTHERWISE SPECIFIED:		NAME	DATE
		DIMENSIONS ARE IN INCHES	DRAWN	K.H.	07.13.11
		TOLERANCES:	CHECKED	J.K.	07.13.11
		FRACTIONAL $\pm$ .015	ENG APPR.	J.K.	07.13.11
		ANGULAR: MACH $\pm$ 2 BEND $\pm$ 2	MFG APPR.	J.K.	07.13.11
		TWO PLACE DECIMAL $\pm$ .005	Q.A.		
		THREE PLACE DECIMAL $\pm$ .003	COMMENTS:		
		INTERPRET GEOMETRIC TOLERANCING PER: ANSI			
		MATERIAL			
NEXT ASSY	USED ON	FINISH			
APPLICATION		DO NOT SCALE DRAWING			

**APW COMPANY**

TITLE:

P/N: EM150-6-212

SIZE  
**A**

DWG. NO.  
**4732**

REV

SCALE: 1:1

WEIGHT:

SHEET 1 OF 1