

## Electrical Specifications

**Voltage:** 115 VAC  
**Duty Cycle:** Continuous  
**Resistance:** 1533 ohms  $\pm$  10% (@ 20c)  
**Amps @ rated Volts:** 0.05  
**Watts @ rated Volts:** 6.0  
**Holding:** 88 lbs (1/4" Thick 1215 CRS @ 20c)  
**Operating Temp:** -40c to 60c (range)

## Additional Components

**Screw:** 10-32 x 1 1/4" Long (Hex Socket Head Cap) w/Nylok  
**Spring:** N/A  
**Spiral Pin:** N/A  
**Potting:** United Resin Corp. (El-cast Black)  
**Finish:** Housing - Zinc or Electroless Nickel Plating (0.0002-0.0003")

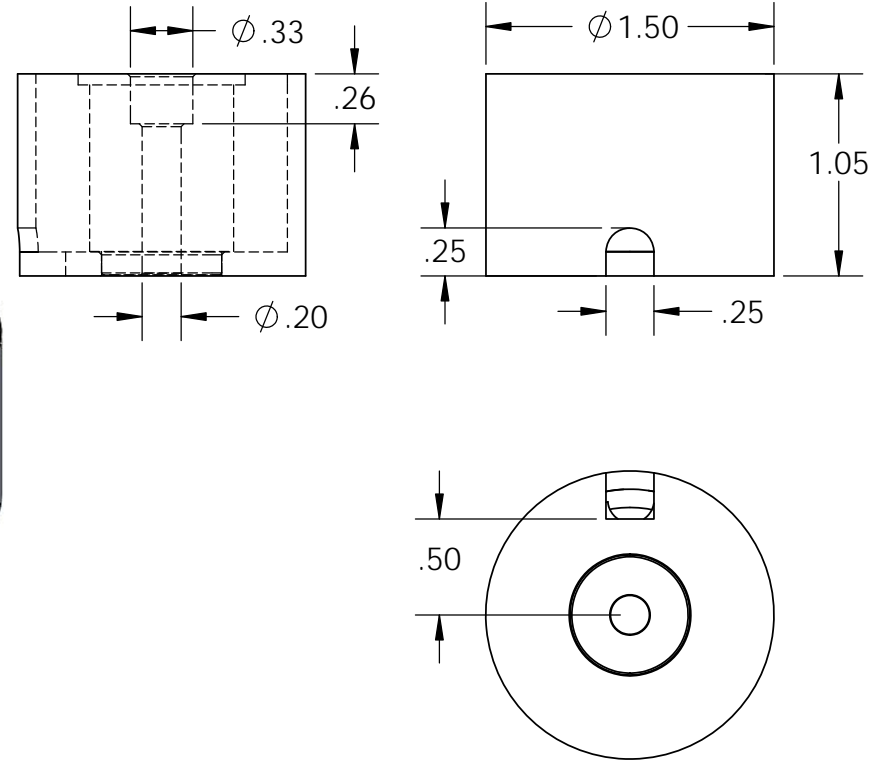

Isometric View

8" from coil to rectifier 11" after 22 Ga. Type 1015 UL

**PROPRIETARY AND CONFIDENTIAL**  
 THE INFORMATION CONTAINED IN THIS DRAWING IS THE SOLE PROPERTY OF APW COMPANY. ANY REPRODUCTION IN PART OR AS A WHOLE WITHOUT THE WRITTEN PERMISSION OF APW COMPANY IS PROHIBITED.

		UNLESS OTHERWISE SPECIFIED:		NAME	DATE	<b>APW COMPANY</b>	
		DIMENSIONS ARE IN INCHES TOLERANCES: FRACTIONAL $\pm .015$ ANGULAR: MACH $\pm 2$ BEND $\pm 2$ TWO PLACE DECIMAL $\pm .005$ THREE PLACE DECIMAL $\pm .003$		DRAWN	K.H.		
		INTERPRET GEOMETRIC TOLERANCING PER: ANSI		CHECKED	J.K.	07.13.11	TITLE: P/N: EM150-115ac-212
		MATERIAL		ENG APPR.	J.K.	07.13.11	
		FINISH		MFG APPR.	J.K.	07.13.11	
NEXT ASSY		USED ON		Q.A.			
APPLICATION		DO NOT SCALE DRAWING		COMMENTS:			
				SIZE	DWG. NO.	REV	
				<b>A</b>	4726		
				SCALE: 1:1	WEIGHT:	SHEET 1 OF 1	