

Electrical Specifications

Voltage: 12 VDC
Duty Cycle: Continuous
Resistance: 235 ohms \pm 10% (@ 20c)
Amps @ rated Volts: 0.07
Watts @ rated Volts: .08
Holding: 5.5 lbs (1/4" Thick 1215 CRS @ 20c)
Operating Temp: -40c to 60c (range)

Additional Components

Screw: N/A
Spring: N/A
Spiral Pin: N/A
Potting: United Resin Corp. (El-cast Black)

Finish: Housing - Zinc or Electroless Nickel Plating
 (0.0002-0.0003")

18" Long Leads
26 Ga. Teflon Type E

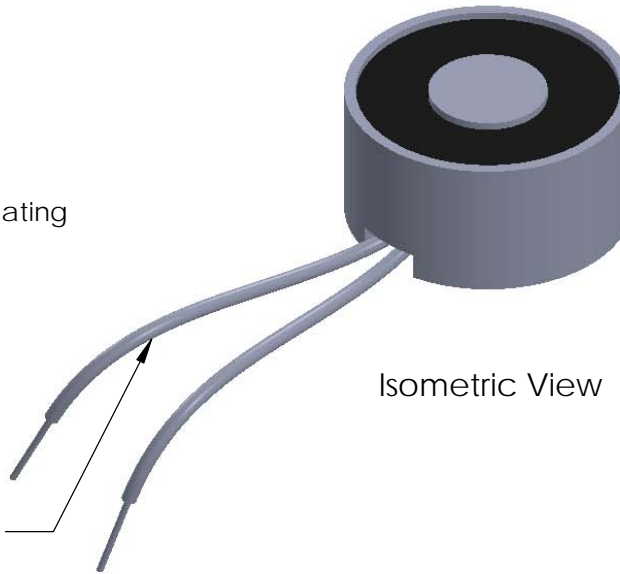

Isometric View

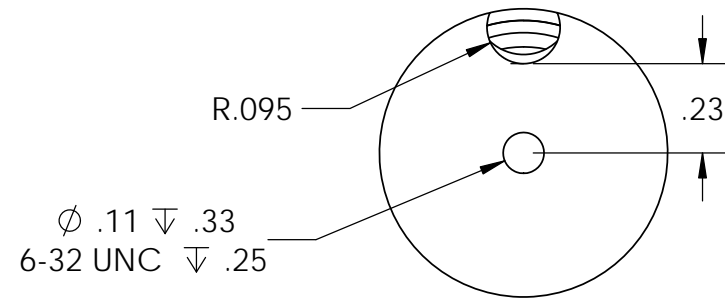
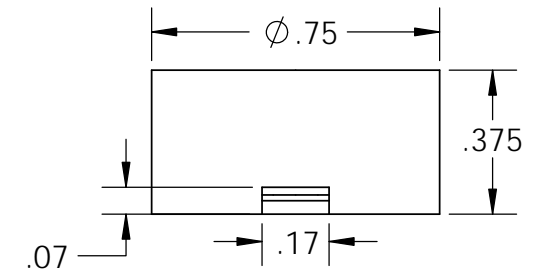
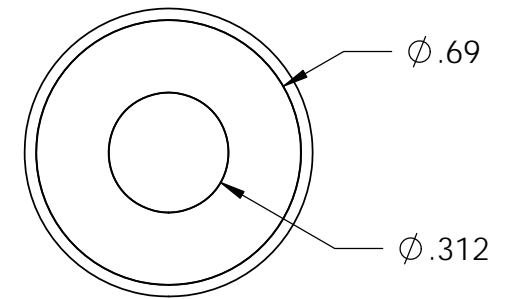

PROPRIETARY AND CONFIDENTIAL
THE INFORMATION CONTAINED IN THIS DRAWING IS THE SOLE PROPERTY OF APW COMPANY. ANY REPRODUCTION IN PART OR AS A WHOLE WITHOUT THE WRITTEN PERMISSION OF APW COMPANY IS PROHIBITED.

		UNLESS OTHERWISE SPECIFIED:		NAME	DATE
		DIMENSIONS ARE IN INCHES TOLERANCES: FRACTIONAL $\pm .015$ ANGULAR: MACH ± 2 BEND ± 2 TWO PLACE DECIMAL $\pm .005$ THREE PLACE DECIMAL $\pm .003$	DRAWN	K.H.	06.29.11
			CHECKED	J.K.	06.29.11
			ENG APPR.	J.K.	06.29.11
			MFG APPR.	J.K.	06.29.11
		INTERPRET GEOMETRIC TOLERANCING PER: ANSI	Q.A.		
		MATERIAL	COMMENTS:		
		FINISH			
NEXT ASSY	USED ON				
APPLICATION		DO NOT SCALE DRAWING			

APW COMPANY

TITLE:

P/N: EM075S-12-212

SIZE
A

DWG. NO.
4597

REV

SCALE: 1:1

WEIGHT:

SHEET 1 OF 1